

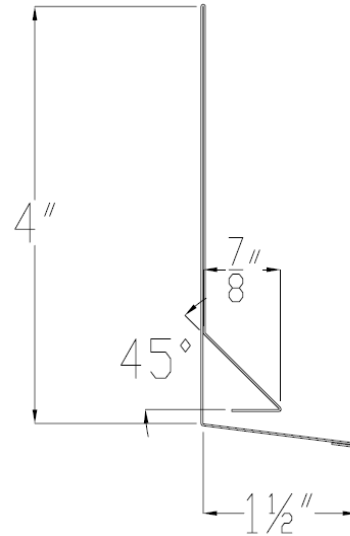

## #17 BASE FLASHING Specification

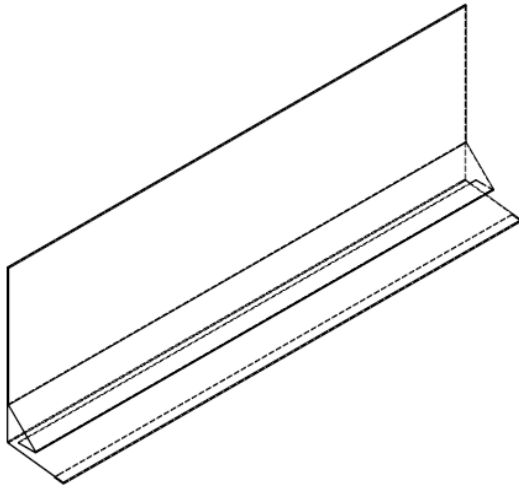

ALL LINE DIMENSIONS IN INCHES U.N.O.

Size	Pcs. / Bundle	Length	Ft. / Bundle	Wt. / Bundle	Pieces/ Pallet
7/8"	10	10'	100	68 lb.	250

The #17 BASE FLASHING is manufactured for application at base of stucco assembly to dissimilar materials. The 45° slope combined with weep holes allows water to weep out of the assembly and the counter flashing leg provides protection to dissimilar materials.

The #17 BASE FLASHING is part of CEMCO's Water Management Products of Stucco Accessories fabricated from minimum 0.018-inch thick premium hot-dipped galvanized steel complying with ASTM A653 having a minimum **G-90** coating complying with ASTM A925.

### CALIFORNIA EXPANDED METAL LATH PRODUCTS CO.

Corporate Office  
263 N. Covina Lane  
City of Industry, CA 91744  
Phone (800) 775-2362  
Fax (626) 330-7598

1001-A Pittsburg Antioch Hwy  
Pittsburg, CA 94565  
Phone (925) 473-9340  
Fax (925) 473-9341

490 Osage Street  
Denver, CO 80204  
Phone (303) 572-3626  
Fax (303) 572-3627